

WB31-2S

WALL BOX 31 FOR TWIN STUD WIDTH

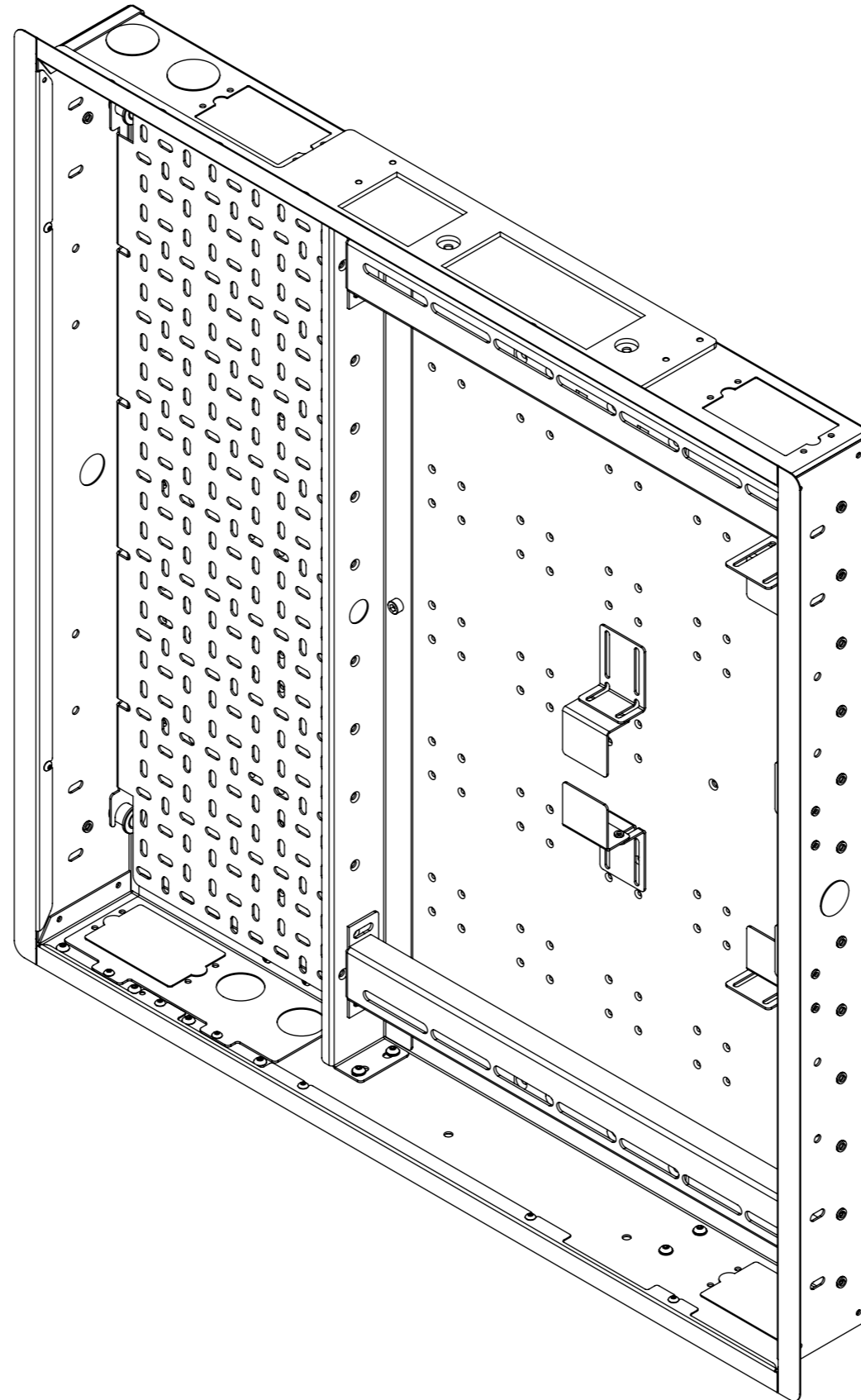

future automation



WB31-2S

WALL BOX 31 FOR TWIN STUD WIDTH



future automation

SPECIFICATION	MEASUREMENTS
Product Dimensions (in wall)	760mm [29 15/16"] W x 792mm [31 3/16"] L x 97mm [3 13/16"] D
PS Bracket Compatilby	PS65, PS55 & PS40
Packaging Dimensions	880mm [34 10/16"] W x 900mm [35 7/16"] L x 180mm [7 1/16"] D
Shipping Weight	29Kg [63lb]
Product Options / Features	Custom RAL paint finishes, WB26-2S, WB31-2S
Package Contents	Wall box with 'hook on' mount plate, 2 x Pairs of clamp brackets, 2 x PS bracket mount rails, 4 x Horizontal trim strips, 2 x Vertical trim strips, 1 x WattBox mount bracket set
Marine Suitable	No

WB31-2S

WALL BOX 31 FOR TWIN STUD WIDTH

DIMENSIONS

Contents include:

- Wall box
- 2 x Pairs of clamp brackets
- 2 x PS bracket mount rails
- 2 x Horizontal trim strips
- 2 x Vertical trim strips
- 1 x WattBox mount bracket set

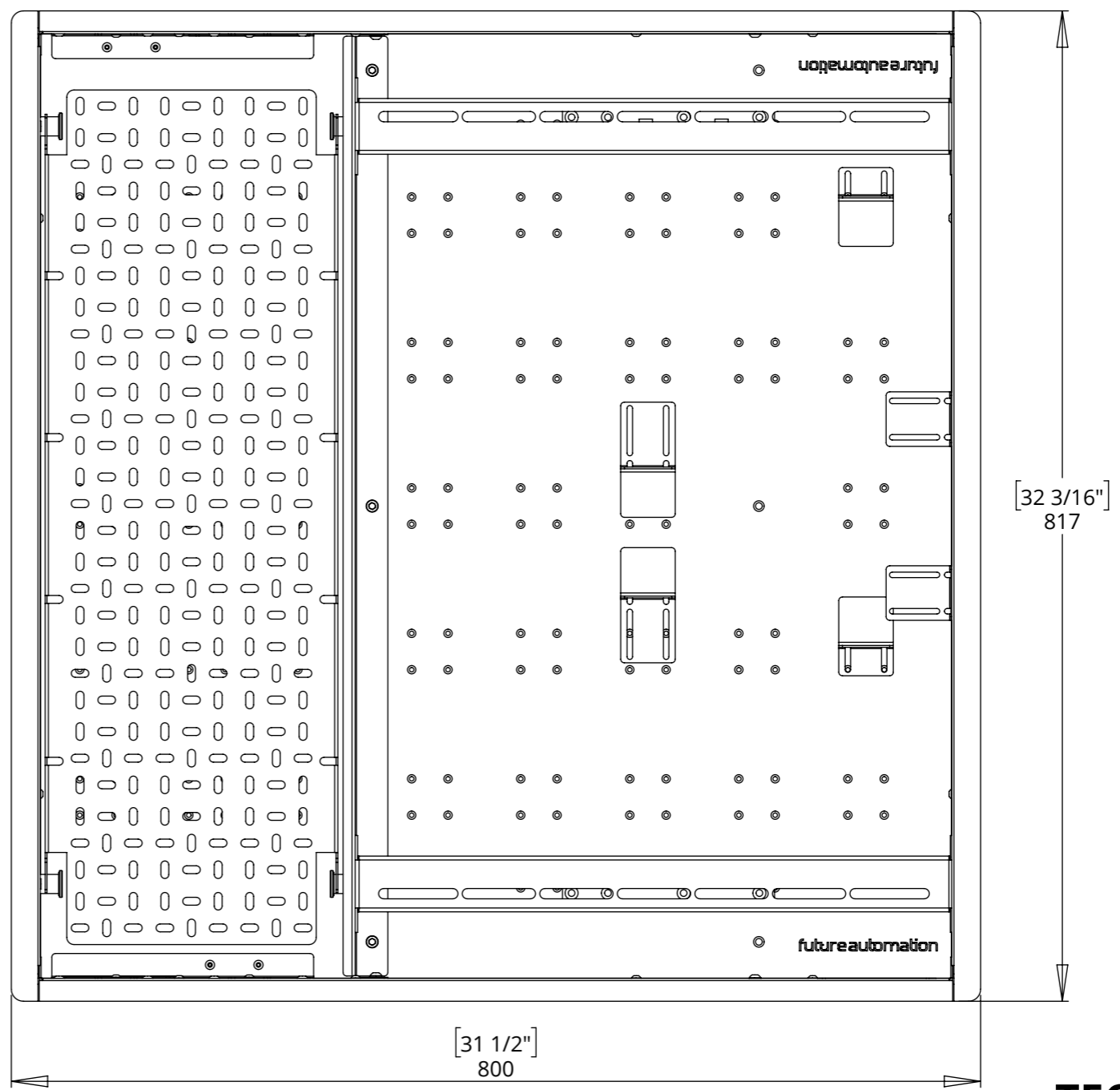
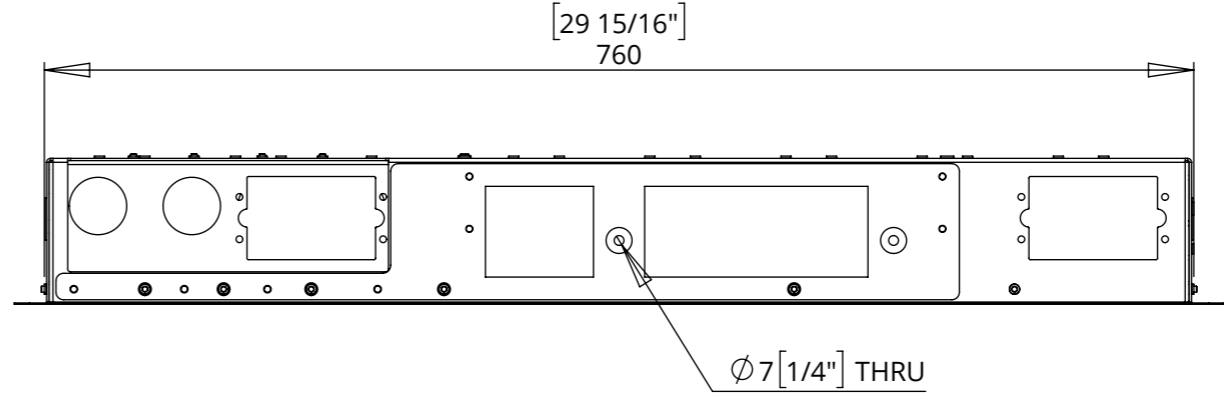
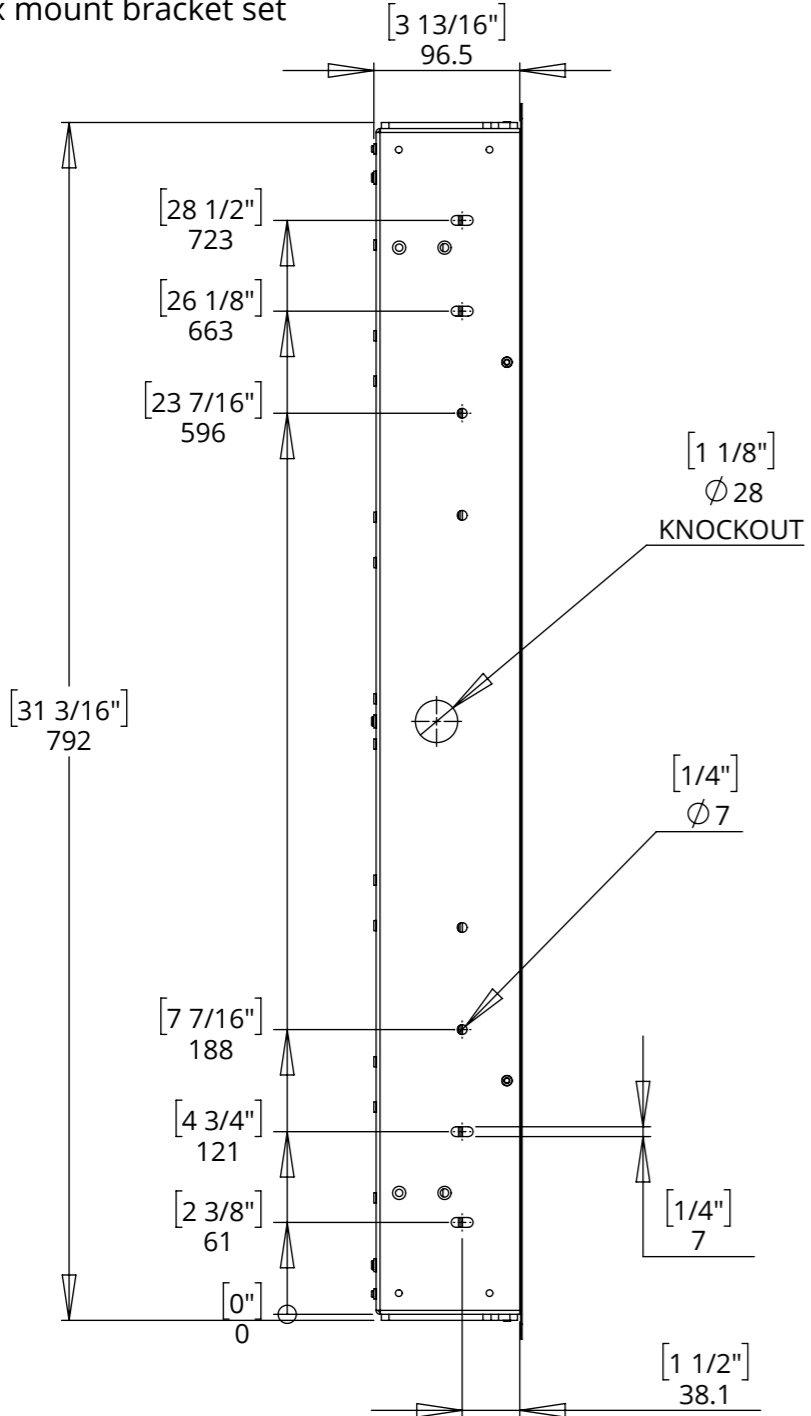

WB31-2S

WALL BOX 31 FOR TWIN STUD WIDTH



future automation

ACCESSORY MOUNTING FEATURES

The WB26-2S features adjustable accessory clamps and a large mounting spaces that means it is perfectly suited to a wide variety of AV accessories.

The removable plate and provided mounting brackets allow the WattBox WB-200/300VB to be mounted into the lower face of any size Wall Box.

These include:

- Samsung One Connect
- Power conditioners e.g BlueBolt SM-3 Pro
- Baluns
- Small audio converters
- Apple TV
- Roku
- SnapAV OVRc compact power conditioner

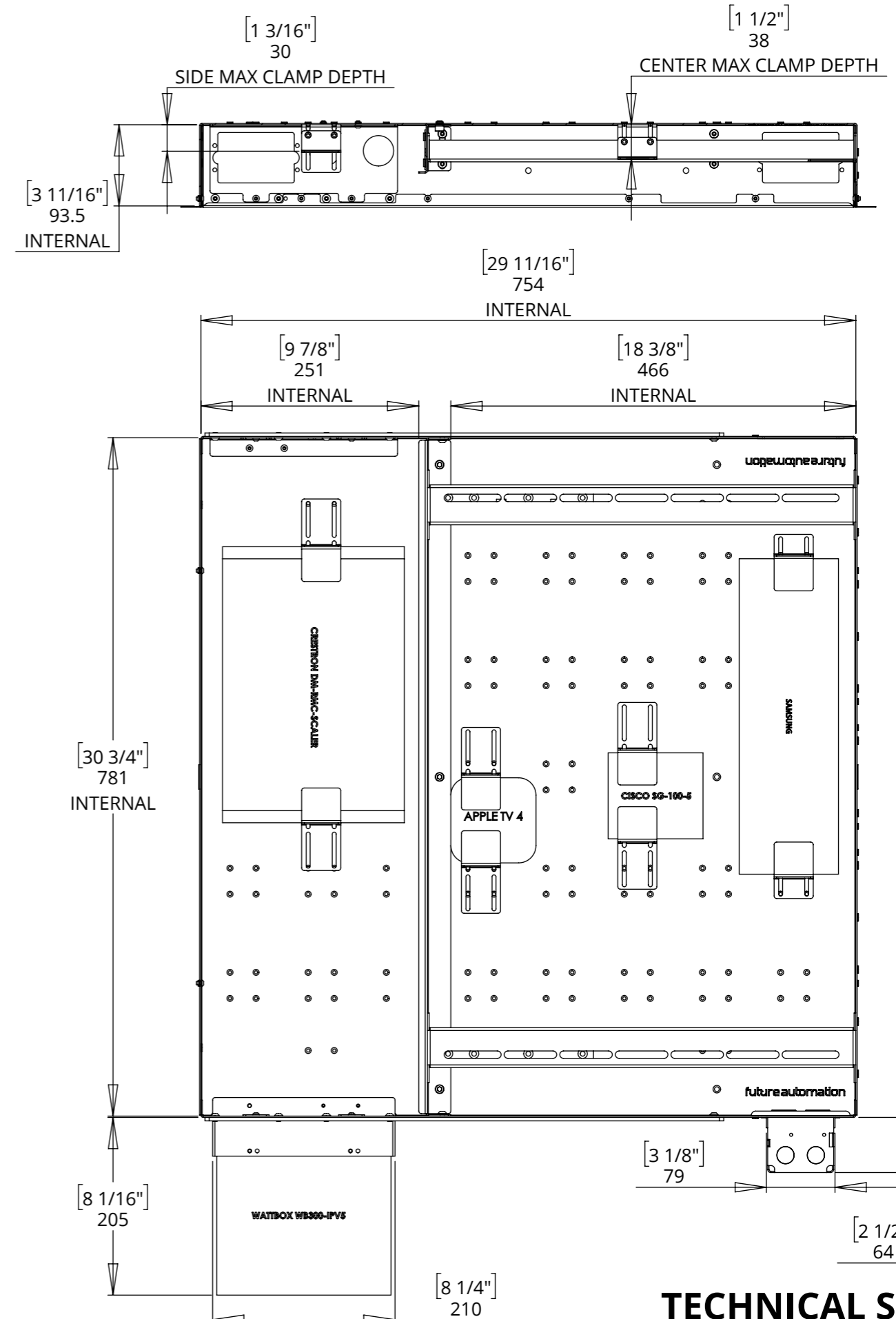
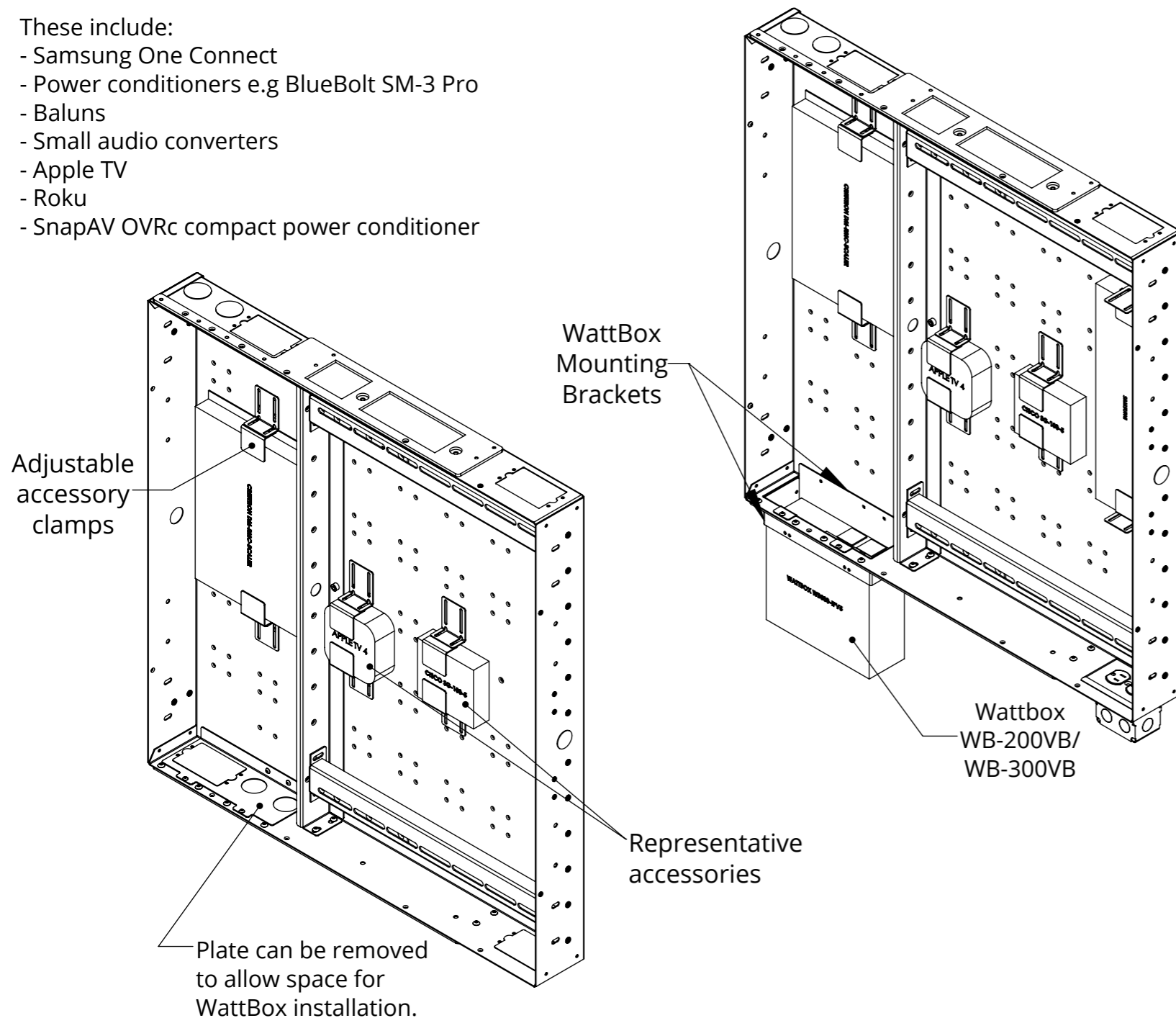

WB31-2S

WALL BOX 31 FOR TWIN STUD WIDTH



future automation

ACCESSORY MOUNTING FEATURES

The WB31-2S also features a removable accessory plate to which accessories can be cable tied to both sides. This plate has two fixed positions to suit a wide variety of AV accessories.

In order to access the removable plate for WattBox mounting, the accessory plate will need to be removed by pulling the top forward, and lifting out of the wall box.

ACCESSORY PLATE

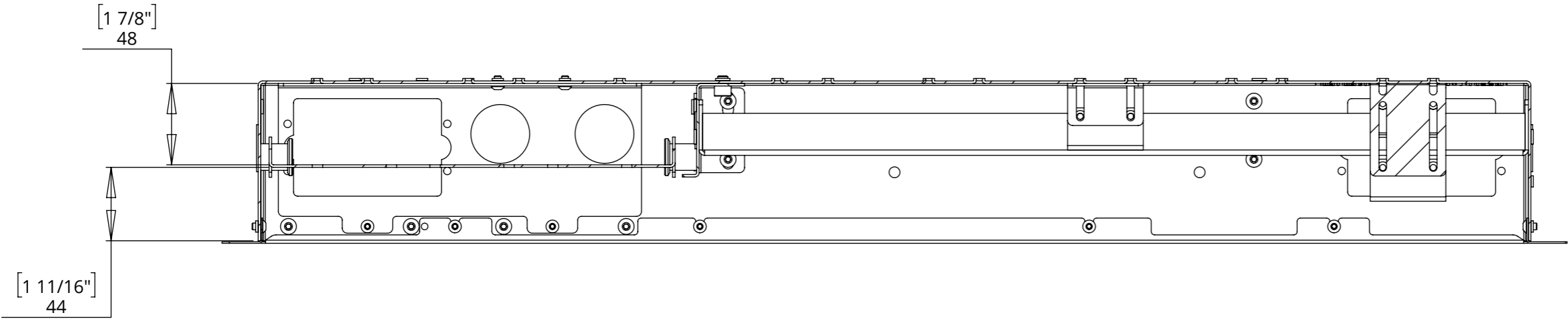
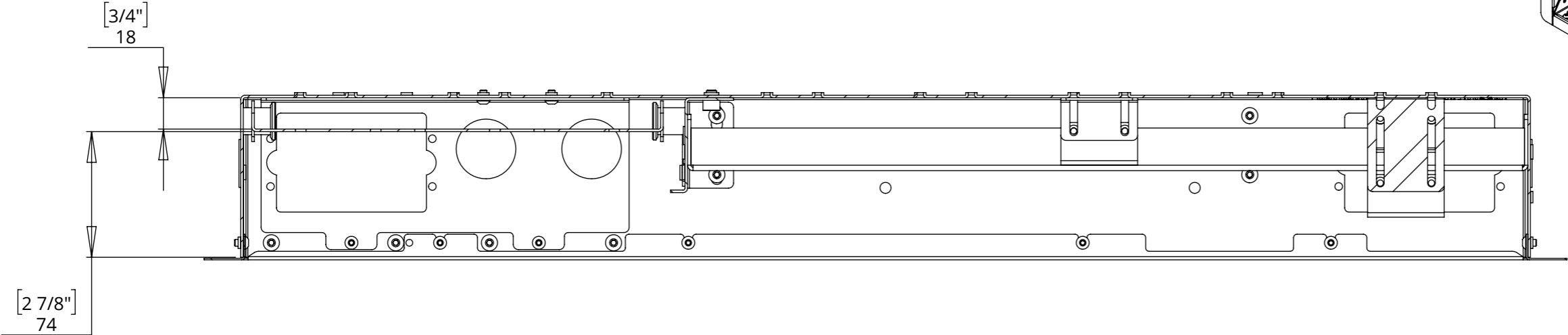
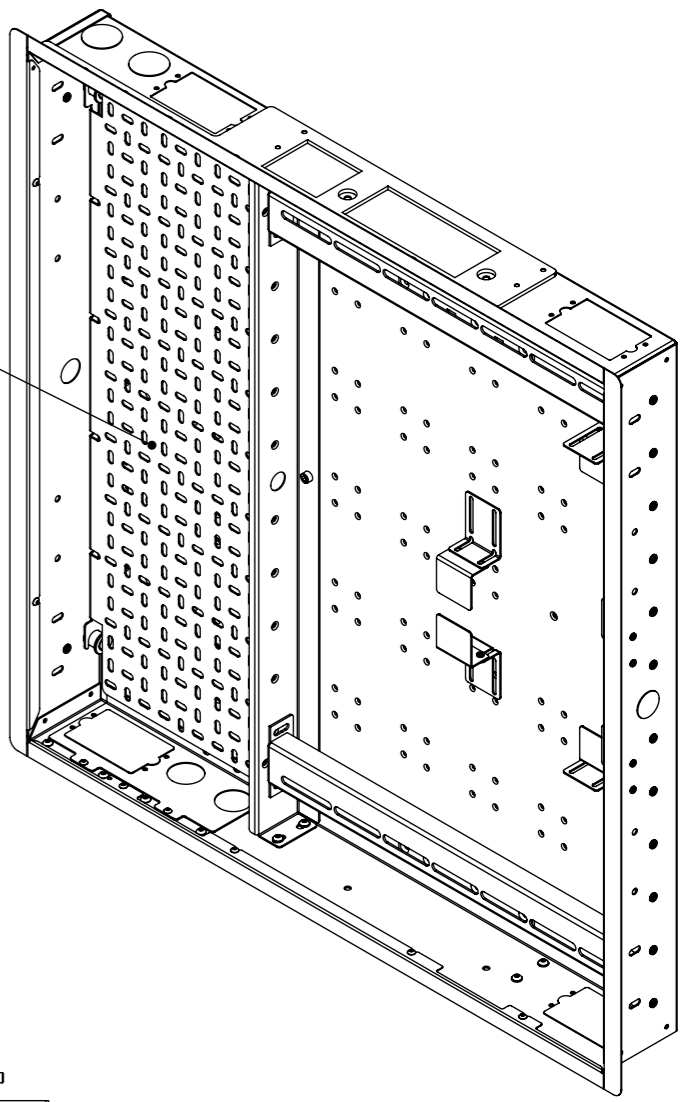

WB31-2S

WALL BOX 31 FOR TWIN STUD WIDTH



ONE CONNECT BOX MOUNTING

2020 One Connect Box

The 2020 One Connect Box can be secured to the Accessory mount plate in the smaller accessory bay.
The provided Clamp Brackets can be used to secure additional accessories inside the larger accessory bay.

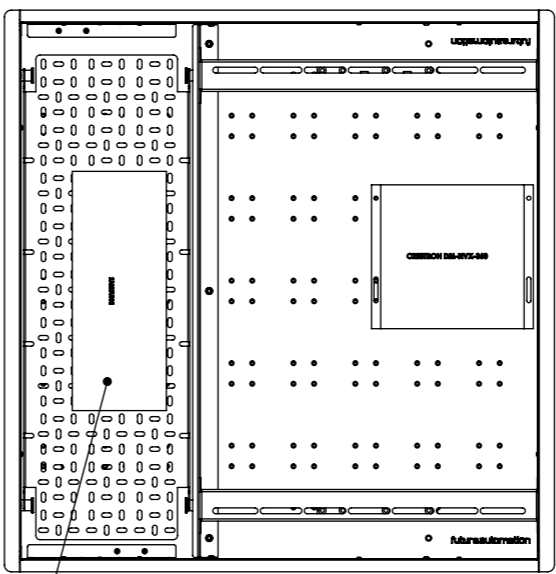
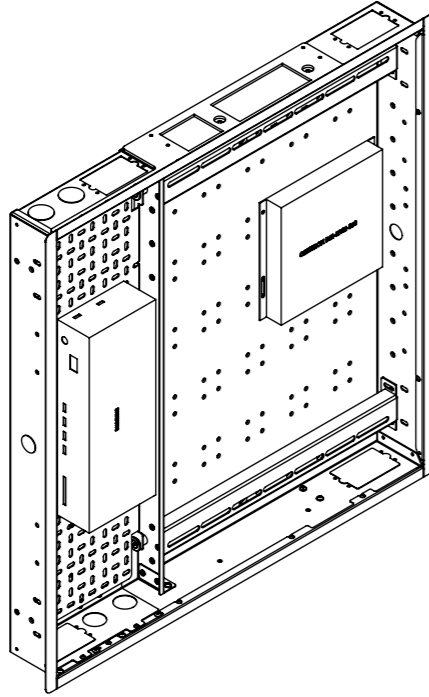

2020 One Connect Box

2021 Slim One Connect Box

The provided Clamp Brackets can be used on the side of the box to secure the 2021 Slim Samsung One Connect Box inside the larger accessory bay.
Note. The 2021 Slim One Connect Box will rest on the lower Mount Rail and will sit partially behind the PS bracket.

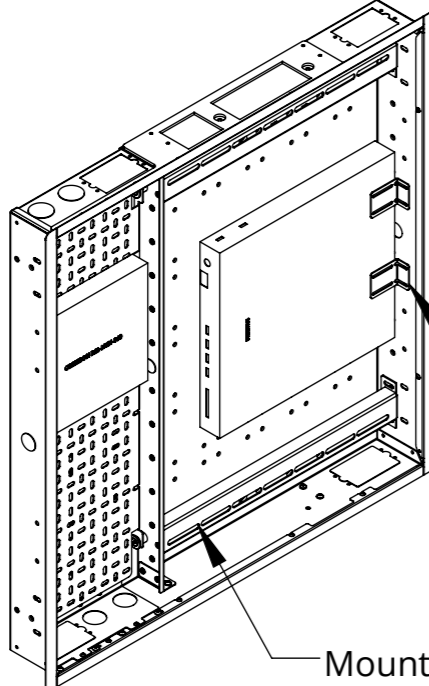

Adjustable accessory clamps

Mount Rail

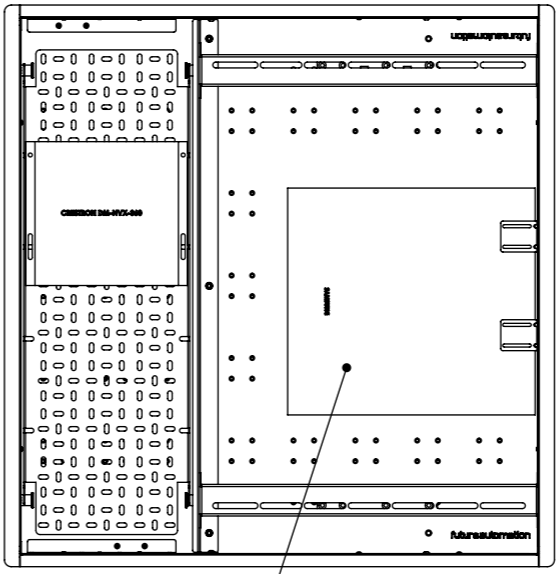

2021 Slim One Connect Box

WB31-2S

WALL BOX 31 FOR TWIN STUD WIDTH



PS BRACKET INSTALLATION FEATURES

LATERAL ADJUSTMENT

The bracket mount rail has slots on the front face to allow the PS bracket to shift laterally so that its location relative to the studs can be fine tuned.

The larger shift side can be to the left or right depending on wall box orientation. Rotate the wall box 180° to determine shift direction.

Shown below with the Future Automation Logo and shift to the right.

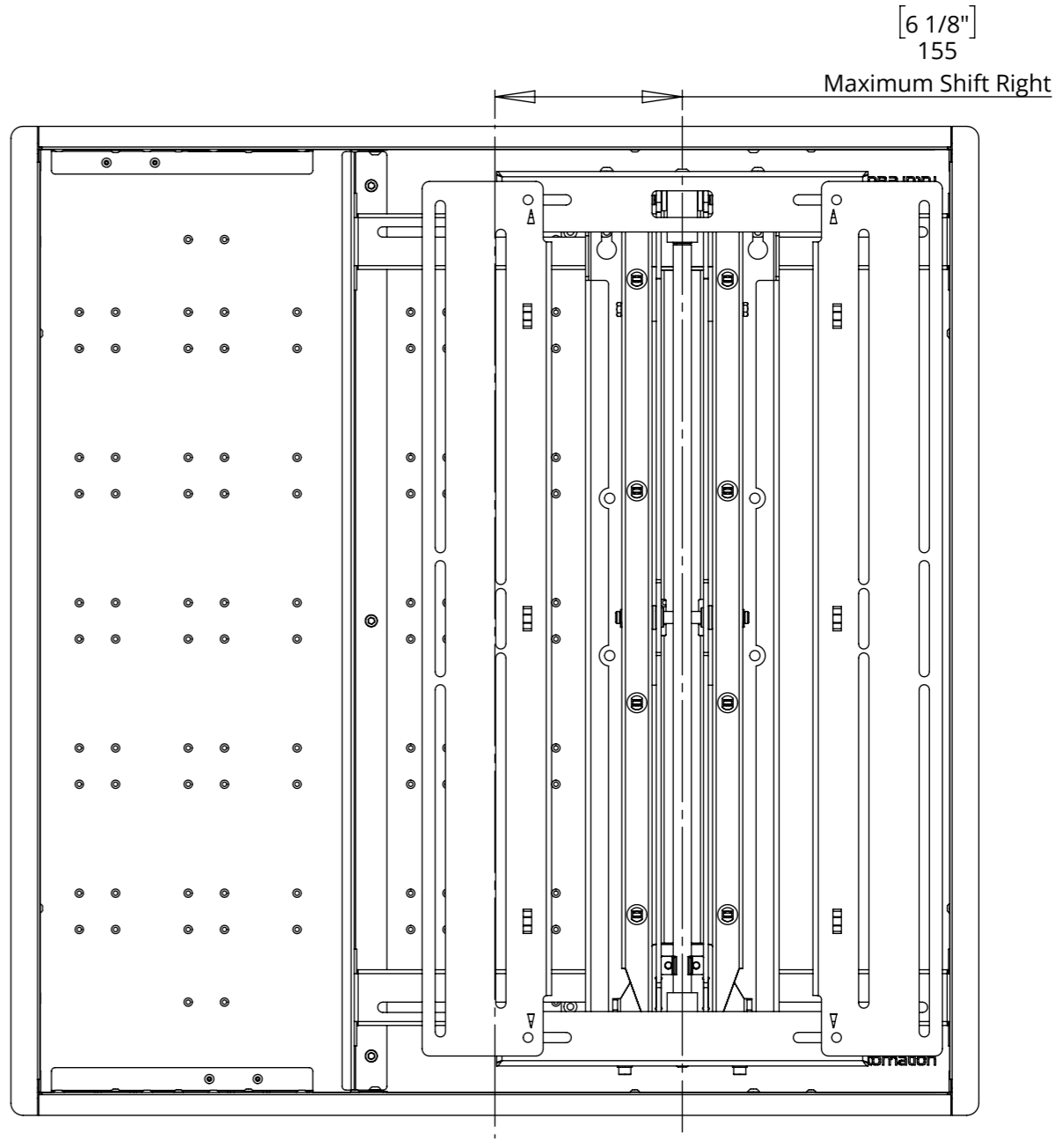
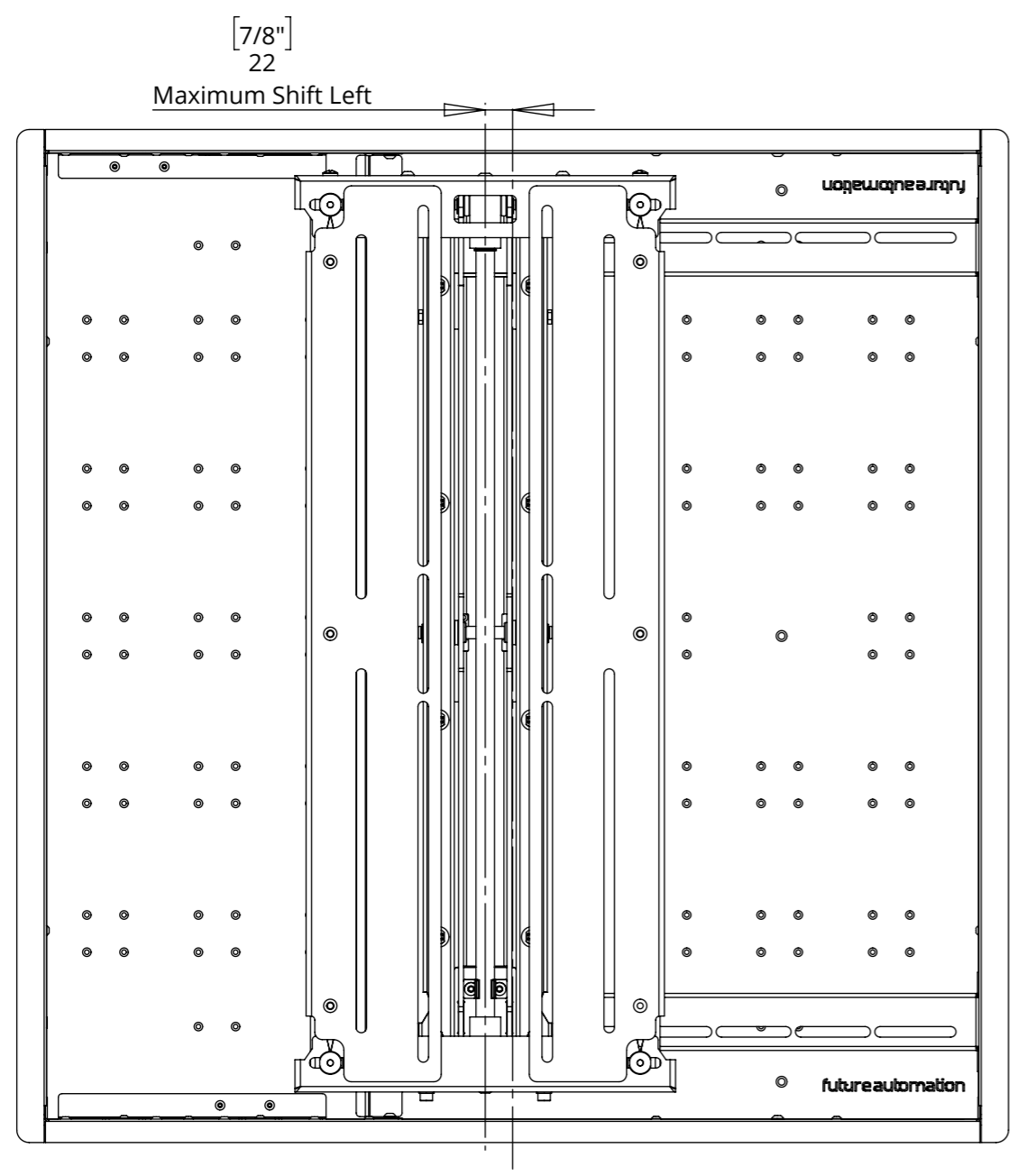

WB31-2S

WALL BOX 31 FOR TWIN STUD WIDTH



future automation

PS40 BRACKET MOUNTING

The PS40 can be mounted in 3 different vertical positions within the wall box as desired to allow more room for accessories

HIGH

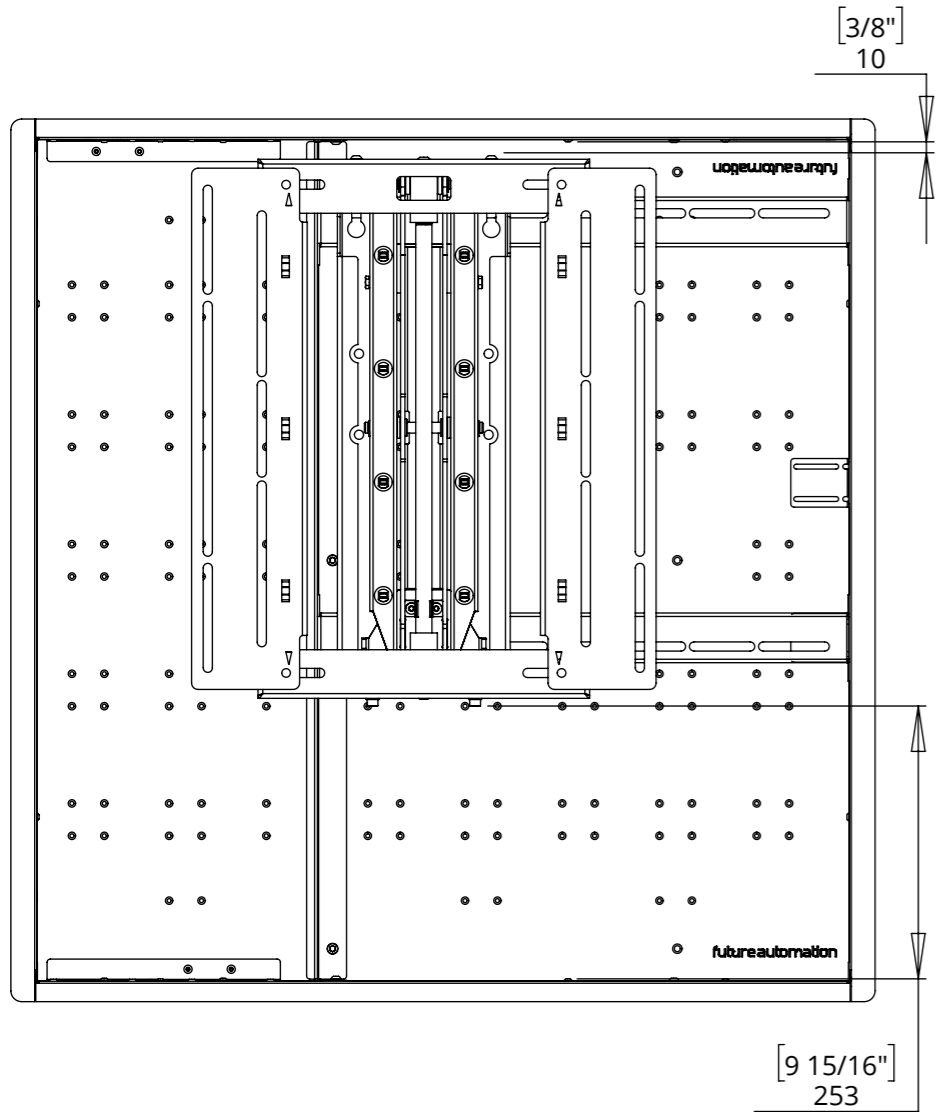

MIDDLE

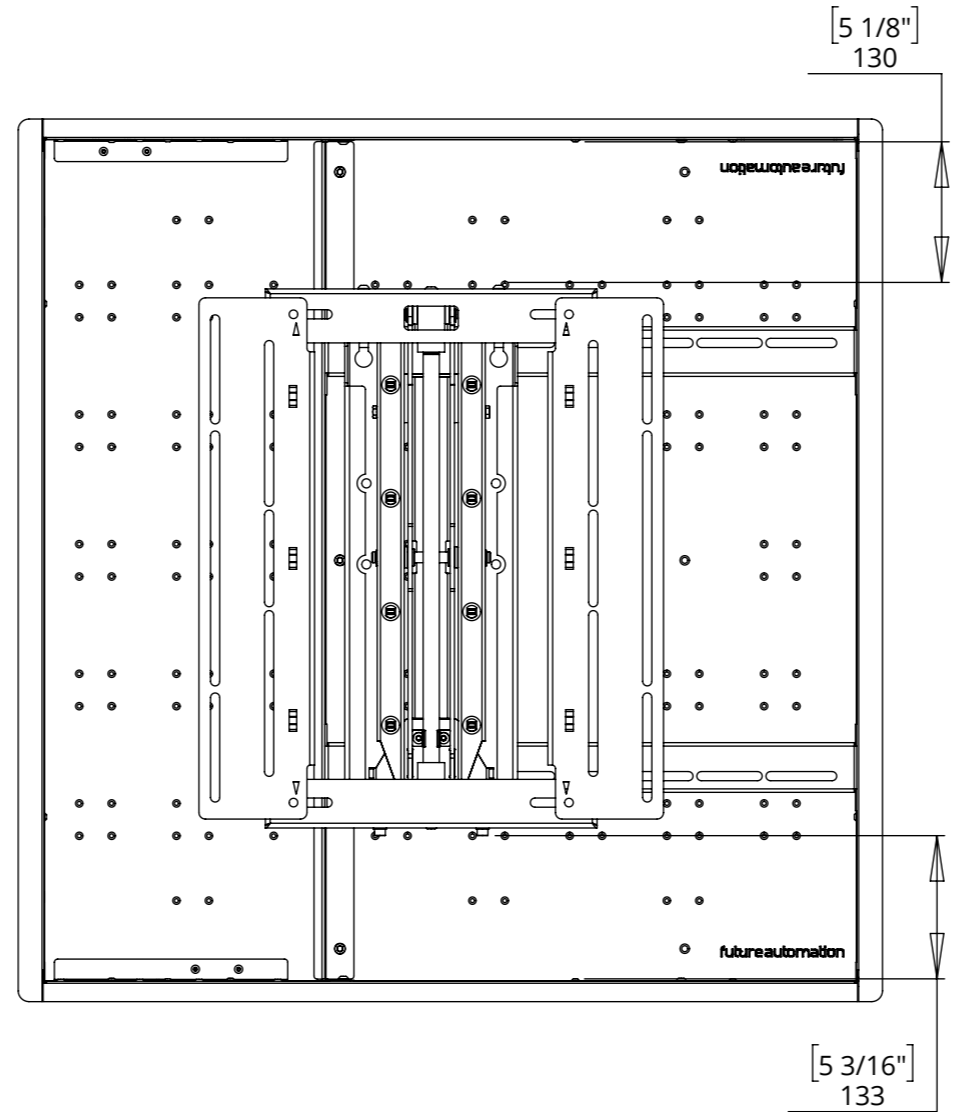

LOW

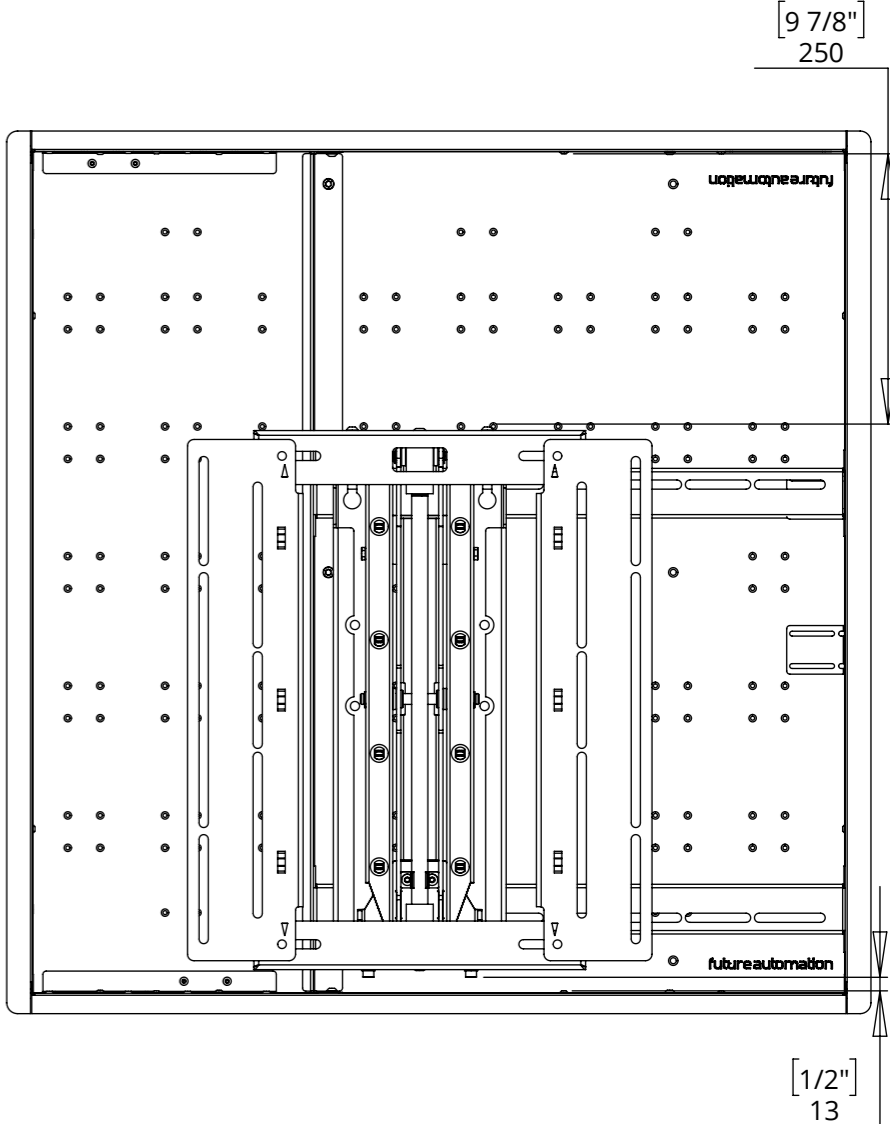

WB31-2S

WALL BOX 31 FOR TWIN STUD WIDTH



future automation

PS55 BRACKET MOUNTING

The PS55 can be mounted in 3 different vertical positions within the wall box as desired to allow more room for accessories

HIGH

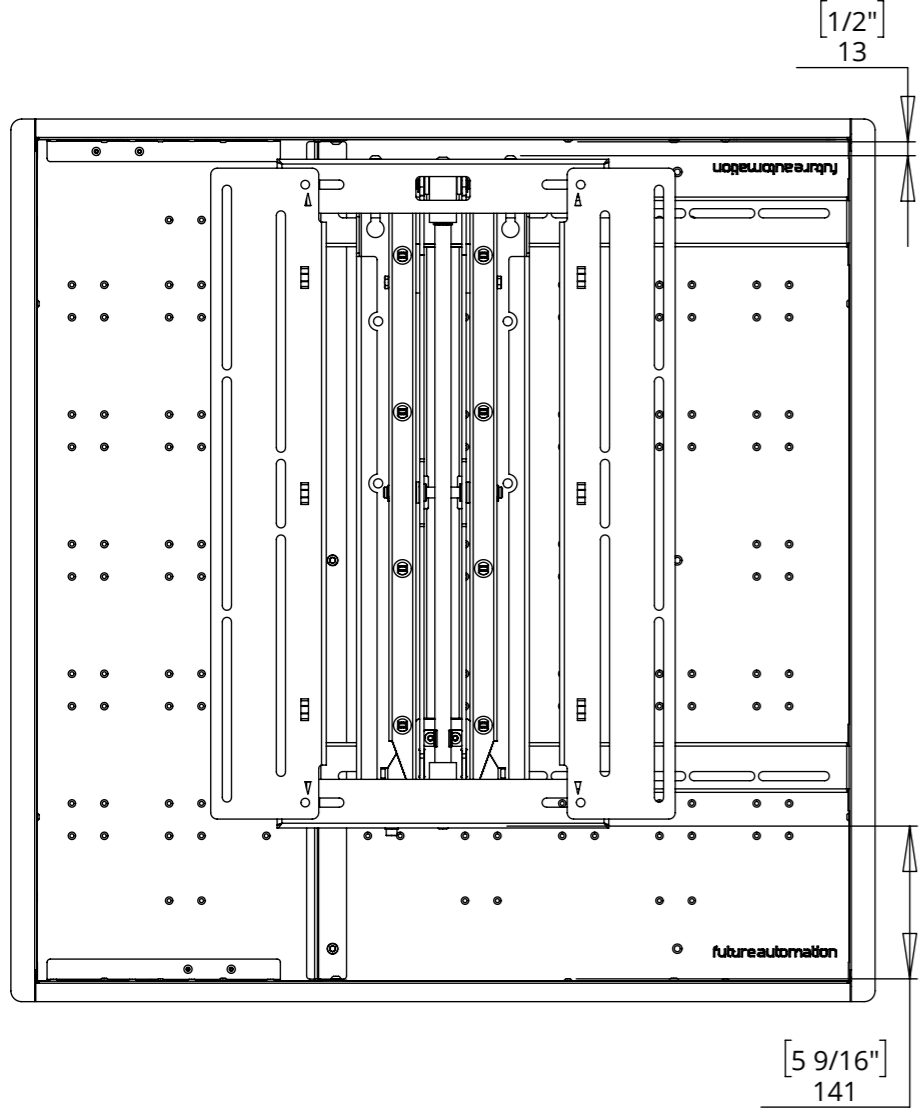

MIDDLE

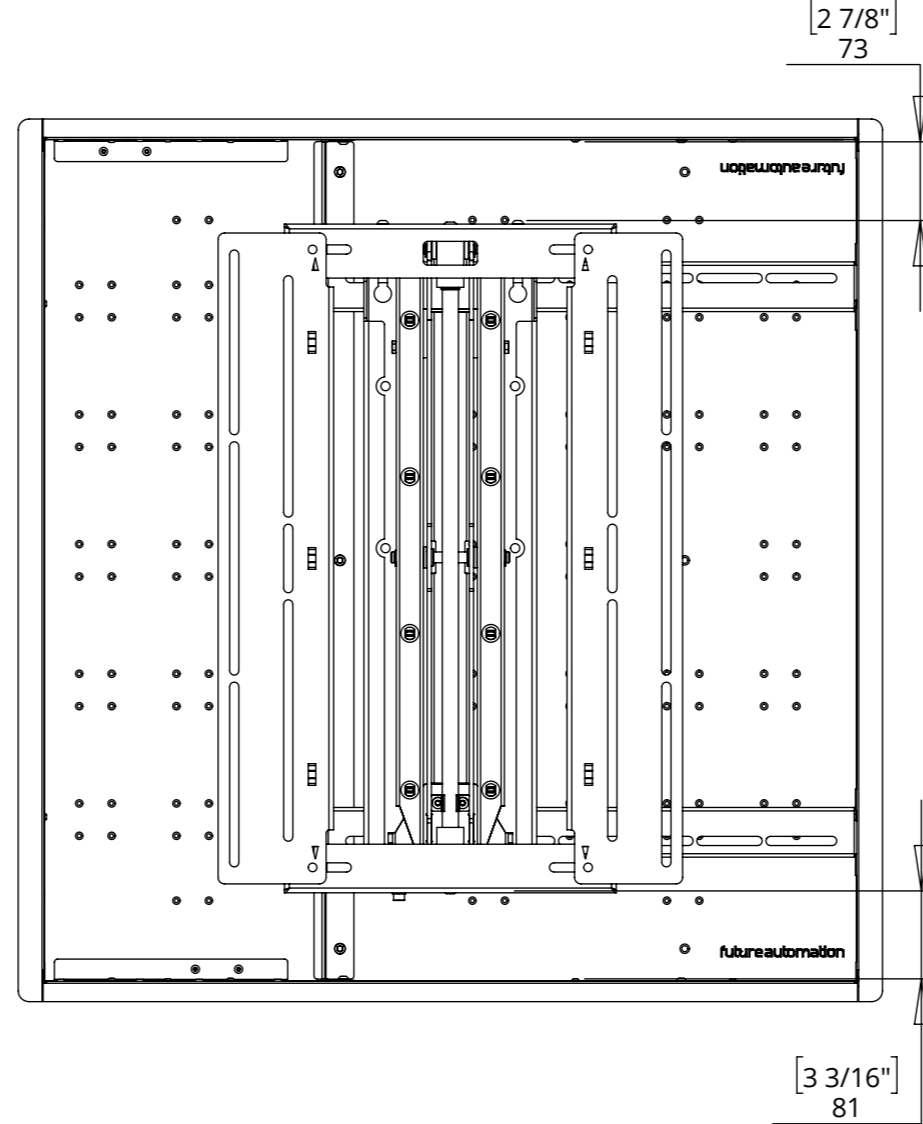

LOW

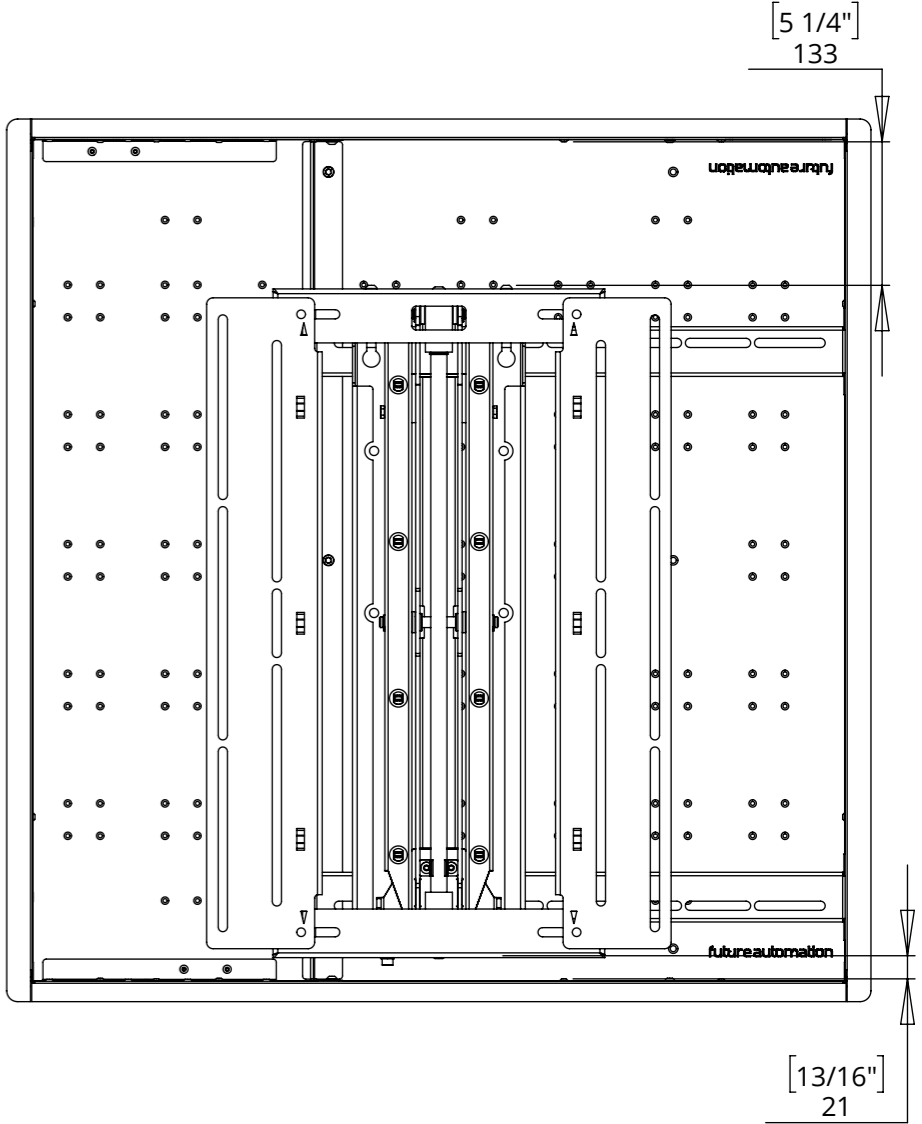

WB31-2S

WALL BOX 31 FOR TWIN STUD WIDTH



PS65 BRACKET MOUNTING

The PS65 has one central mounting position within the WB31-2S wall box.

